

## Holder / No. 810

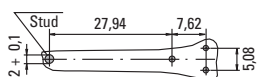

Horizontal / 3-Pin



Holes in the printed circuit board: 1,3 +0,1

## PC Mount, Shocksafe 5x20mm / 6.3x32mm Fuses

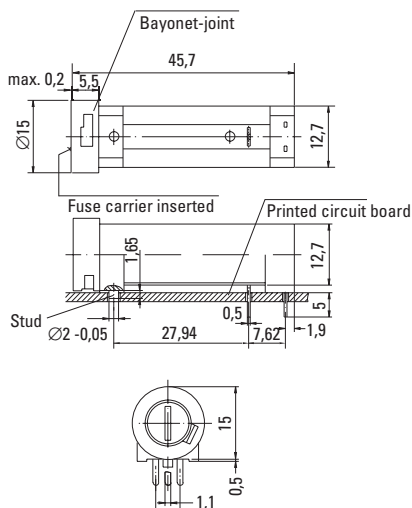

## Cap / No. 815



For 5x20mm Fuses

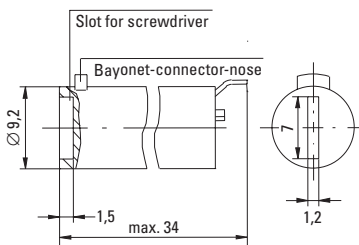

## Cap / No. 816



For 6.3x32mm Fuses

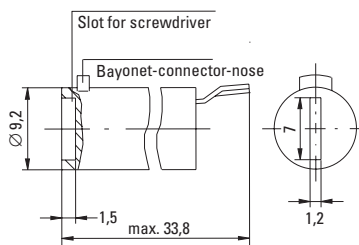

## Specifications

### Standard

IEC 60127-6  
UL 512  
CSA C22.2. No.39

### Approvals

VDE: License No. 118611  
SEMKO: Certificate No. 9932039  
UL Recognized: File No. E 70164  
CSA Certified: File No. 47574



### Mounting

(3) Solder pins 0.5mm x 1.1mm and plastic stud  
The pins spaced at 5.08mm form a common connection.

### Protection Class & Category

IP 40 (IEC 60529)  
PC2 (IEC 60127-6)

### Materials

Holder/Cap: Black Thermoplastic  
Polyamide PA 6.6, UL 94V0  
Metal Parts: Copper alloy,  
corrosion protected  
Terminals: Solderable, tinned

### Electrical Data (23°C)

Rated Voltage: 250V  
Rated Current: 6.3A (VDE/SEMKO)  
16A (UL/CSA)  
Rated Power : 2.5W (VDE/SEMKO)

### Operating Temperature

-25°C to +70°C (consider de-rating)

### Climatic Test

-25°C/+70°C/21 days (IEC 60068-2-1...3)

### Stock Conditions

+10°C to +60°C  
relative humidity ≤ 75% yearly average,  
without dew, maximum value for 30 days - 95%

### Vibration Resistance

24 cycles at 15 min. each (IEC 60068-2-6)  
10 - 60Hz at 0.75mm amplitude  
60 - 2000Hz at 10g acceleration

### Contact Resistance

≤ 5mΩ

### Dielectric Strength

> 1.5 kV

### Impulse Voltage

4 kV, 50 Hz, 1 min., dry

### Insulation Resistance

> 10<sup>3</sup> MΩ (500 VDC, 1 min.)

### Solderability

235°C, 3 sec. (Wave)  
350°C, 1 sec. (Soldering Iron)

### Soldering Heat Resistance

260°C, 5 sec. (IEC 60068-2-20)

### Minimum Cross Section

Conducting path - 0.2mm<sup>2</sup>

### Marking

810, 250V, Approvals

### Unit Weight

5.4g (Holder) / 2.5g (Cap)

## Order Information

### Packaging

Bulk (100 pcs.)

### Order Numbers

Holder	No. 810 0000 000
Cap, 5x20mm	No. 815 0000 000
Cap, 6.3x32mm	No. 816 0000 000

## WebLinks

### Data Sheet

[www.wickmann.com/products/810.pdf](http://www.wickmann.com/products/810.pdf)

### Approval Certificates

[www.wickmann.com/approvals](http://www.wickmann.com/approvals)

### FaxBack Document # 506